

COMPACT Dynamic

Instructions for use

EN | 200004297 | 2023-09

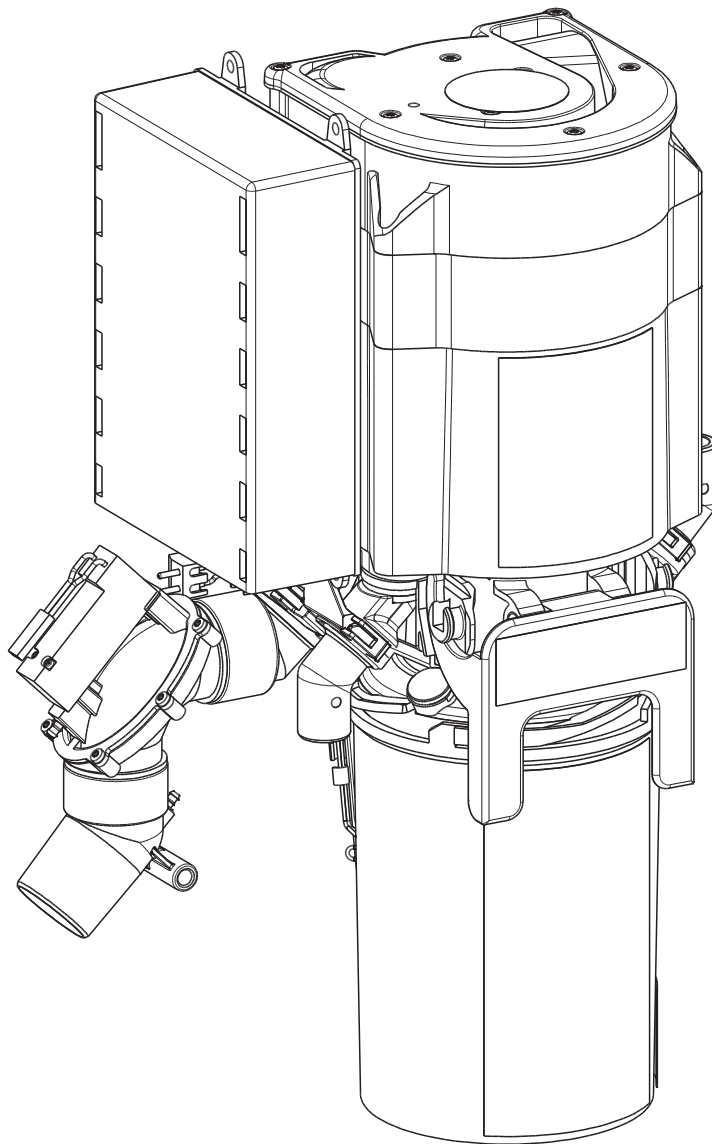

eIFU:
www.metasys.com/downloads





METASYS
protect what you need

Table of contents

1.	Notes	4
1.1.	General instructions	4
1.2.	Explanation of the symbols	4
2.	Intended use	6
2.1.	Indication	6
2.2.	Contraindication	6
2.3.	Target group	6
3.	Safety-related information	7
3.1.	General safety-related information	7
3.2.	Safety instructions	7
3.3.	Warnings	7
4.	Product description	8
4.1.	Product description	8
4.2.	Technical data / performance data	8
4.3.	Type plate	8
4.4.	Construction	9
4.5.	Functional description	9
4.6.	Diagram	10
5.	Preparation for use	11
5.1.	Transport and storage	11
5.2.	Installation requirements	11
5.2.1.	Assembly variants	12
5.2.2.	Pipe and hose connections	12
5.2.3.	Connection dimensions	13
5.2.4.	Filter	13
5.3.	Installation, assembly and commissioning	14
5.3.1.	Installation and assembly of optional accessories, retrofit parts and spare parts	15
5.3.2.	Connecting to other devices	15
5.4.	Electronics	16
5.4.1.	Electrical connections	16
6.	Use	17
6.1.	Normal operation	17
6.1.1.	External display	17
6.2.	Error messages	17
7.	Care and maintenance	19
7.1.	Regular cleaning measures	19
7.1.1.	Daily cleaning with GREEN&CLEAN M2	19
7.1.2.	Cleaning and emptying the prefilter	19
7.2.	Maintenance and service	19
7.2.1.	Replacement of the collection container	20
7.2.2.	Disposal of the collection container	22
7.2.3.	Service mode	23
7.2.4.	1-year service kit	23
7.2.5.	5-year service kit	24
7.2.5.1.	Visual check of the centrifuge	25
8.	Decommissioning	26
8.1.	Disassembly	26
8.2.	Recycling and disposal	26
9.	Annex	27
9.1.	Order numbers and scope of delivery	27
9.1.1.	Accessories, service kits, collection containers and spare parts	27
9.2.	Warranty conditions	36
9.3.	Change history	36

eIFU

		eIFU: www.metasys.com/downloads
		DE, EN, FR, IT, BG, CS, DA, EL, ES, ET, FI, HR, HU, LT, LV, NL, NO, PL, PT, RO, SK, SL, SV
	e-mail	ifu@metasys.com
	Order number	200004297

If you would like to request a printed copy of the instructions for use, please contact us at ifu@metasys.com or use the order form at www.metasys.com/downloads. A hardcopy of the instructions for use will be made available to you free of charge and within seven calendar days of receipt of the request.

Translations

Translation of the original instructions for use

Tetras GmbH
 Sirius Business Park, Rupert-Mayer-Str. 44, 81379 Munich, Germany

Images

The images contained in these instructions for use are for reference and may differ from the actual appearance of the product.

1. Notes









































1.1. General instructions

METASYS can only guarantee the safety, reliability and performance of the dental device if the following instructions are adhered to:

- > The product is only to be used in accordance with the instructions for use.
- > During maintenance and service work (inspection, service, repair, replacement), only use original replacement parts.
- > All manufacturer specifications for the treatment units to which the device is connected must be observed.
- > After commissioning, complete the proof of installation and send this to METASYS in order to define the warranty period.
- > All maintenance and service work must be entered into the device logbook.
- > On request by an authorised technician, METASYS will provide all documentation that may be of use to technically qualified personnel during maintenance and service works
- > METASYS accepts no responsibility for damage that may arise due to external influences (defective installation), using incorrect information, improper use of the dental device, or maintenance and service works being carried out improperly.
- > The user must familiarise himself/herself with how to operate the dental device and ensure that the dental device is in good condition each time before operating it.

Important: Read the accompanying documents of the device carefully before installation, commissioning and use and keep them for the entire service life of the product!

1.2. Explanation of the symbols

 CE mark	 End device ready for operation	 Use eye protection
 Medical device	 Loudspeaker	 Use mouth and nose protection
 Item number	 Sound	 Unplug from mains
 Serial number	 Inclination / slope	 General warning sign
 Manufacturer	 Maximum installation altitude	 Warning of electrical voltage
 Date of manufacture	 Blower / fan	 Information
 Follow instructions for use	 On Off	 Download
 Follow instructions for use with reference to eIFU eIFU: www.metasys.com/downloads	 Separate collection of electrical/ electronic equipment (WEEE)	 Do not cut
 Temperature limit	 Protective earthing	 Maintenance / service
 Caution / attention	 Protection class II	 Stop operation
 Beware of electric shock	 Applied part type BF	 Protect from heat / Protect from sunlight
 Humidity limit	 Mark of conformity per para. 22 section 4 Lower Saxony Building Regs	 Protect from moisture / Store in a dry place
 Tank filled	 Responsible for the translation	 Fragile
	 Observe instructions for use	 Package orientation at the top



Fault on end device



Use hand protection



Stacking limit n = (quantity)



Unique identifier of a medical device



UDI marking with standard compliant HIBC data content

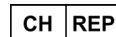

Name and address of the authorized representative's registered office in Switzerland

1.3. Copyright notice

All names and contents are protected by copyright. Distribution, duplication or alternative use of this document is only permitted with the written consent of METASYS Medizintechnik.

2. Intended use

The METASYS COMPACT Dynamic is a software-controlled two-step single-unit amalgam separator with integrated dynamic air/water separation, as well as a suction flow valve for separating amalgam from the waste water of dental treatment units.

2.1. Indication

Not applicable.

2.2. Contraindication

Not applicable.

2.3. Target group

The device shall be used by trained and qualified personnel exclusively.

3. Safety-related information

3.1. General safety-related information

All serious incidents related to the device must be reported to the manufacturer and the competent authority of the Member State where the user and/or the patient is resident.

3.2. Safety instructions

Assembly, modifications or repairs may only be carried out by authorised qualified personnel who guarantee compliance with the EN 60601-1 standard (international standard on Medical Electrical Equipment and Systems, in particular part 1: General requirements for basic safety).

The electrical installation must comply with the regulations of the IEC (International Electrotechnical Commission).

Medical devices should be handled with care with regard to electromagnetic compatibility. Special safety measures must therefore be taken.

The device is not suitable for operation in explosive areas or in flammable atmospheres.

3.3. Warnings

Danger	Warning of a danger that will directly result in serious injury or death
Warning	Warning of a danger that can result in serious injury or death
Caution	Warning of a danger that can result in minor injury
Attention	Warning of a danger that can result in extensive damage to property

4. Product description

4.1. Product description

COMPACT Dynamic a two-stage single place amalgam separator with integrated dynamic air/water separation.

4.2. Technical data / performance data

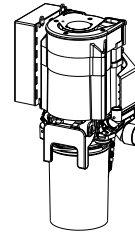
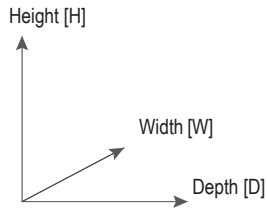

	COMPACT Dynamic
Power supply	24 V AC
Frequency	50/60 Hz
Max. current consumption	4 A
Max. power consumption	100 VA
Max. ambient temperature	40 °C
Max. liquid flow rate	3.0 l/min via the spittoon; 1.5 l/min via the suction side
Negative pressure range	80-160 mbar
Separation rate	96,4 %
Collection container volume	300 cm ³
Dimensions (H x W x D)	301 x 173 x 110
Class	MD class 1
DIBT approval number	Z-64.1-2
Possible suction systems	Wet or dry suction systems

4.3. Type plate

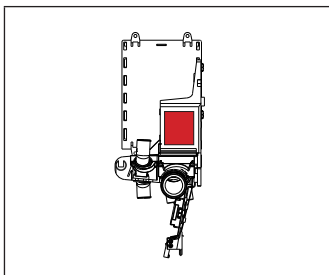

COMPACT Dynamic Built-in version:

The type plate is located on the right side of module 1 (above the connection of the suction hose).

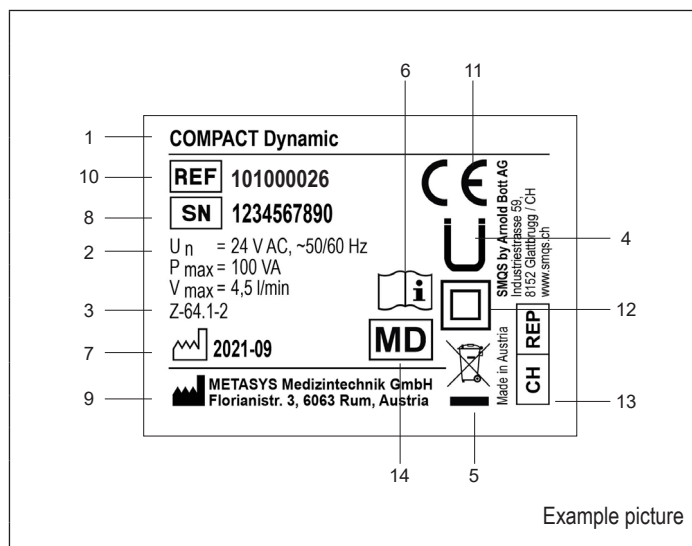

- 1 Device description
- 2 Connection data
- 3 Registration number Deutsches Institut für Bautechnik (DIBT) (German Institute of Construction Technology)
- 4 Mark of conformity per para. 22 section 4 Lower Saxony Building Regs
- 5 Separate collection of electrical/electronic equipment (WEEE)
- 6 Follow instructions for use
- 7 Date of manufacture
- 8 Serial number
- 9 Manufacturer
- 10 Item number
- 11 CE mark
- 12 Protection class II
- 13 Name and address of the authorized representative's registered office in Switzerland
- 14 Medical device

4.4. Construction

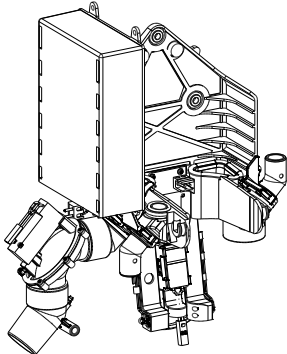
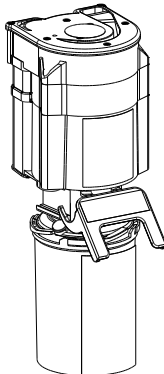
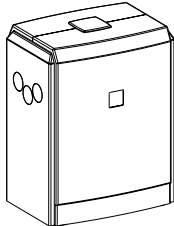
Module 1	Module 2
<p>Central fastening element:</p> <ul style="list-style-type: none"> > Air, water and electrical connections > Wall mount > Main board > Diagnostic board > Filter unit 	<p>Air/water separation:</p> <ul style="list-style-type: none"> > Collection container > Centrifuge > Separation unit
	
	<p>Cover</p> <p>Cover (optional)</p>

4.5. Functional description

The wastewater from the spittoon bowl is fed directly into the collection container, where the first stage of amalgam separation (by sedimentation) takes place.

As soon as the liquid level in the collection container reaches the effective range of the capacitive sensor, the motor is started, which drives the pump as well as the centrifuge and the impeller. The pump conveys the water, which has been pre-cleaned by sedimentation, into the centrifuge.

During rotation, the heavy particles are pushed against the walls of the two centrifuge chambers, wherein one is located inside the other. The filtered water is continuously drained into the outlet.

After a run-on time, the motor is short-circuited and the centrifuge is thus abruptly stopped. Due to the continuing rotation of the water column, a self-cleaning effect occurs in the centrifuge, which flushes the heavy particles into the collection container.





When a suction hose is lifted off, the place selection valve is opened and the motor is started. Thus, the pump, the centrifuge and the separation impeller are set in rotation. The suction stream is passed through the separation chamber and accelerated in a circular motion by the fast rotating blades of the impeller.

The solid and liquid components of the suction stream are thrown out tangentially, while the air passes through the blade axis to the suction machine.

The ejected solids and liquids are fed to the centrifuge via an inlet hopper and the cycle described above starts again.

4.6. Diagram

Legend

-  Suction flow (secretion)
-  Negative pressure
-  Waste water
-  Amalgam
-  Waste water with amalgam

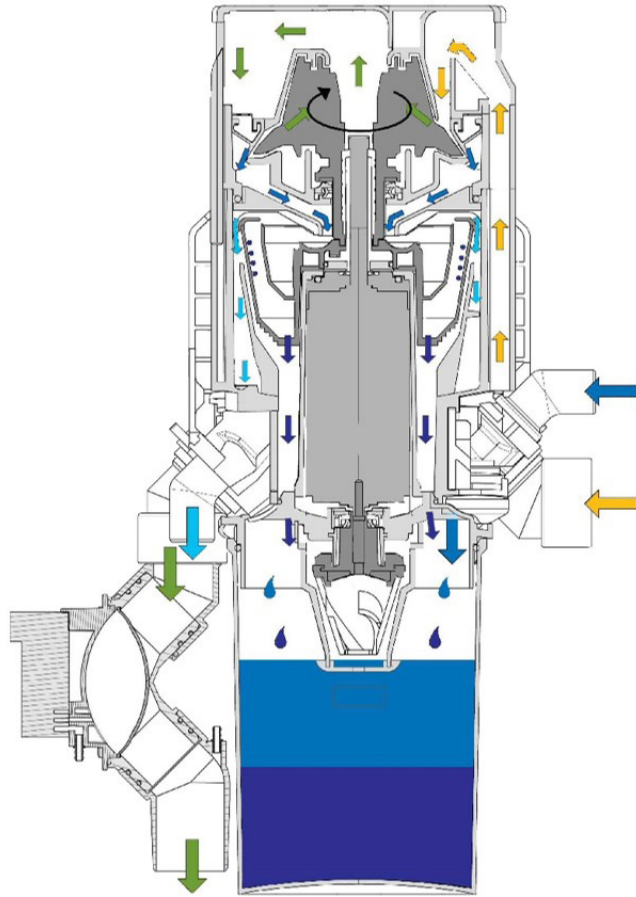

5. Preparation for use

5.1. Transport and storage

The device is shipped in two polystyrene shells fixed together. This original packaging must be used for any onward and return transport. The device must always be transported and stored in an upright position. The device must be transported to the installation site in a completely packed state. After unpacking the device, check for completeness and possible transport damage.

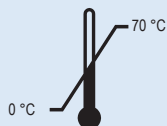

Transport and storage temperature



Transport and storage humidity limitation

5.2. Installation requirements

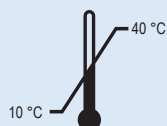

Operating temperature: 10°C to 40 °C



Humidity limit max. 70 %



Max. 3,000 m above sea level

- > The following space requirement must be provided for the installation: H x W x D = 350 mm x 215 mm x 120 mm
- > To avoid vibrations, use only the three holes on module 1 to attach to load-bearing parts of the treatment unit! (Do not remove vibration inserts!)
- > The device must be able to swing freely and must not have any contact with other parts of the treatment unit (cables, hoses, covers, etc.).



Caution:

A contact protection plate must be fitted behind module 1 if the subsurface is electrically conductive!

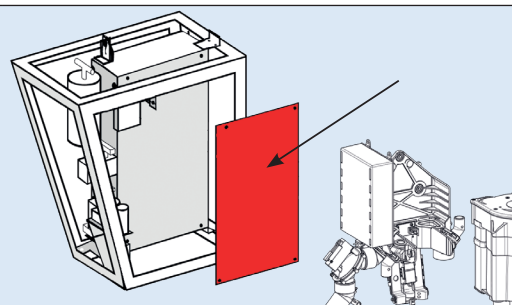

5.2.1. Assembly variants

	<p>Installation in the spittoon</p> <p>Direct integration of the device into the spittoon should be used as the preferred solution, as the tubing routes to the device can be kept as short as possible.</p> <p>In the spittoon, ensure vibration-free suspension of the device from supporting parts of the treatment unit.</p>
	<p>Installation in the behind the patient's head</p> <p>If there is no spittoon at the treatment chair and the suction system is located behind the head of the patient, the device can be installed inside a cabinet.</p> <p>In this case, the connection opening for the spittoon drain must be closed with a blind plug.</p>
	<p>Set-up with cover (optional)</p> <p>If it is not possible to install the device directly in the treatment unit, the set-up can also be carried out in the optionally available cover.</p> <p>The cover should be mounted on the connection box of the treatment unit. The external display and a transformer are already integrated in the cover.</p>

5.2.2. Pipe and hose connections

COMPACT Dynamic Built-in version		COMPACT Dynamic with cover	

- 1 Connection for spittoon drain hose Ø 15 mm
- 2 Connection for suction hose (for hose storage) Ø 26 mm
- 3 Connection for suction hose (to suction machine) Ø 26 mm
- 4 Connection for drain hose (clean water outlet) Ø 15 mm



Attention:

Unused connections must be sealed with blind plugs!

- > The hose routes leading to the device must be kept as short as possible to prevent pre-sedimentation.
- > Dirty dental hoses must be replaced during installation and disposed of by an approved disposal company.

- > The device must be connected to the sewage pipe via an odour trap.
- > The waste water must be able to flow freely, as the separation efficiency is not guaranteed in the event of backwater.
- > Water jet operated saliva ejectors must be shut down due to high water consumption.
- > The flushing of the spittoon must be limited by means of a timer or button to max. 30 seconds at a max. water flow of 3 l/min to enable the centrifuge to stop.
- > For matching hose adapters and fittings see 9.1.1. Accessories, service kits, collection containers and spare parts.

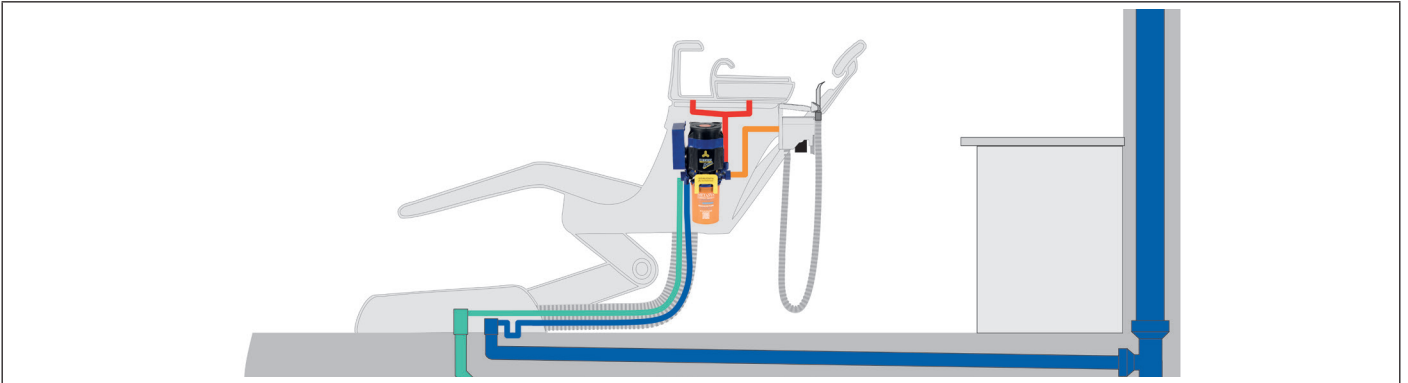

5.2.3. Connection dimensions

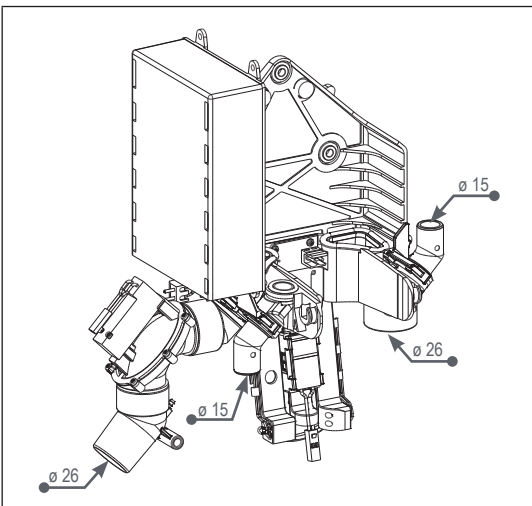

5.2.4. Filter

There must be a coarse filter in the drain of the spittoon. This must have a mesh size of max. 3 mm and must not be removed while the amalgam separator is in operation.

If not present in the hose storage, a pre-filter with a mesh size of max. 1 mm must be installed on the suction side of the amalgam separator. The pre-filter must be easily accessible for the practice staff.

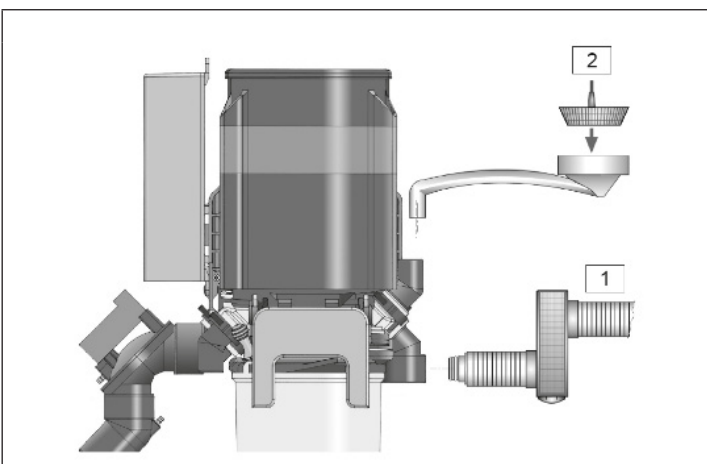

- 1 Pre-filter
- 2 Coarse filter (spittoon)

5.3. Installation, assembly and commissioning

Read the instructions carefully before installation and commissioning!



- 1 Meet spatial requirements

see 5.2. Installation requirements

- 2 Check the coarse filter in the spittoon

- 3 Install the pre-filter (if not present in the hose storage)

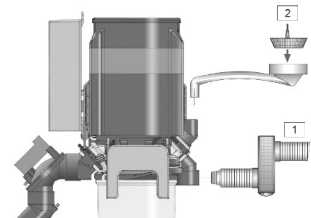

COMPACT Dynamic Built-in version

- 4 Fit a contact protection plate behind module 1 (if the subsurface is electrically conductive)

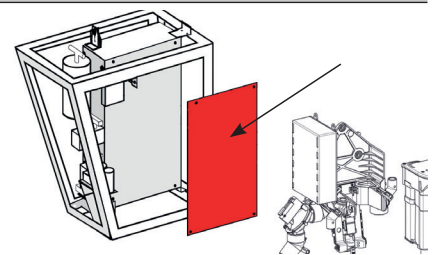

- 5 Connect the spittoon drain hose
(Mesh size of the coarse filter max. 3 mm)

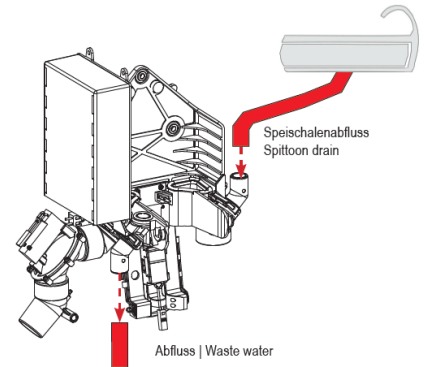

- 6 Connect the drain hose

- 7 Connect the suction line from the hose storage (suction hose)

- 8 Connect the suction line to the suction machine (suction hose)

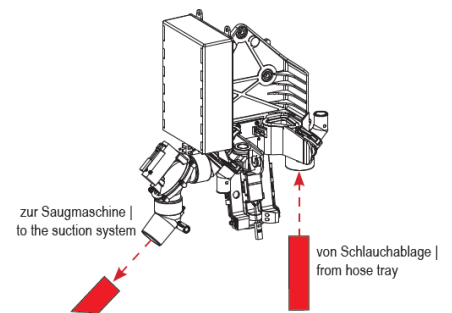

- 9 Connect electrical connections (see 5.4. Electronics)

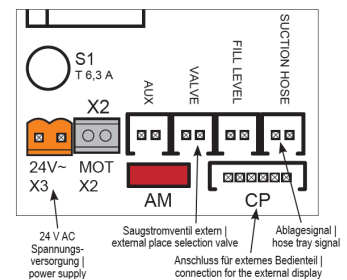

- 10 Switch on the device via the device or practice main switch.
The centrifuge of the COMPACT Dynamic starts up briefly and stops abruptly (self-test).

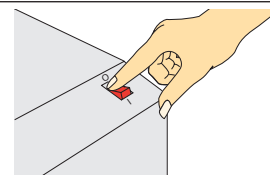

- 11 When LED 1 lights up green, the amalgam separator is ready for operation (for a description of the external display, see 6.2.1. External display).

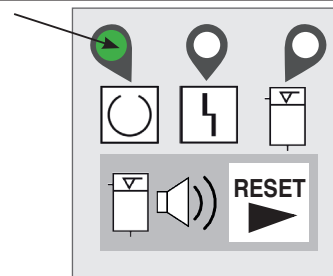

Inform the dentist about product function, operation, care and warranty conditions.

- 12 Fill in the installation proof and device logbook and return them to METASYS (installation@metasys.com)



- 13 Perform normal operation test see 7.2.3. Service mode

5.3.1. Installation and assembly of optional accessories, retrofit parts and spare parts



Assembly, modifications and repairs may only be carried out exclusively by authorised specialist personnel (see 3.2. Safety instructions)! The METASYS technical customer service is also available for further information and assistance in carrying out repairs, retrofitting, fault analyses, etc.

5.3.2. Connecting to other devices

When connecting the METASYS device to other devices or systems, hazards can arise. It must therefore be ensured that no hazards arise for the user or the patient and that the environment is not affected. The specifications of the manufacturer of the device or system to be connected must be observed.

5.4. Electronics

The mains connection may only be carried out by a qualified electrician. The electrical installation must be carried out in accordance with the applicable local regulations. Before connecting to the mains, compare the rated voltage on the device type plate with the mains voltage.

5.4.1. Electrical connections

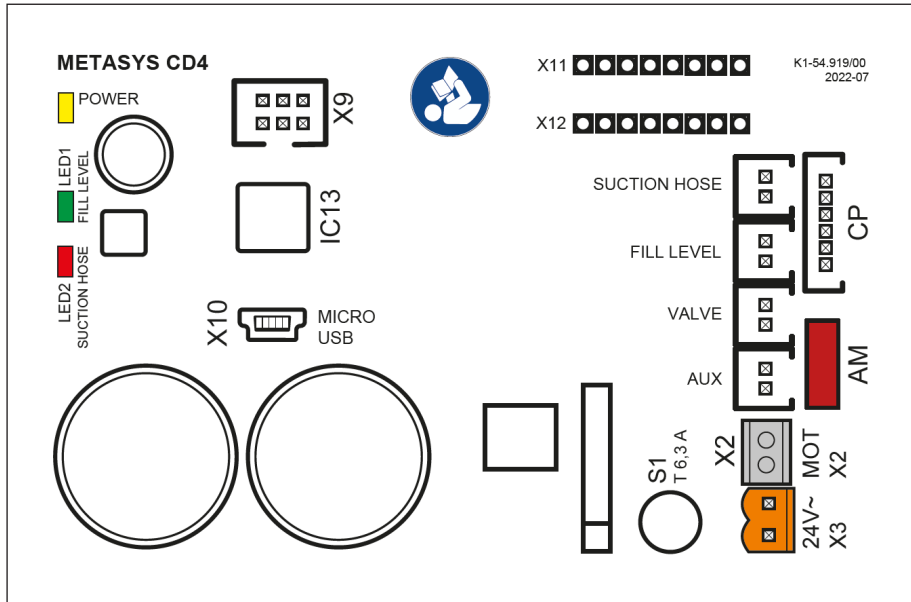

LED 1	LED fill level
LED 2	LED suction hose
X1 (fill level / water level)	Filling level
X2	Motor connection
X3 (main power)	Power supply 24 V AC
	The supply voltage must be taken from a safety transformer that complies with the requirements of IEC 601-1 / VDE 0750 Part 1 / DIN EN 60601-1 and IEC 60742 + A1 / DIN EN 60742.
X4 (suction hose)	Storage signal
X5 (CP)	Connection for external control unit
X6	Aux
X7 (valve)	Suction flow valve
X8 (AM)	Light barriers filling level amalgam
X9	Programming connector
X10	Micro-USB connector
X11	no function
X12	no function
S1	Fuses may only be replaced by the same type!



Danger:

The supply voltage must be taken from a safety transformer that complies with the requirements of IEC 601-1 / VDE 0750 Part 1 / DIN EN 60601-1 and IEC 60742 + A1 / DIN EN 60742.

Danger:

Fuses may only be replaced by the same type!

6. Use

6.1. Normal operation

Ensure that the device is switched off at least 1 x per working day for level measurement. The 24 V AC power supply must be connected after the device's or practice's main switch.

6.1.1. External display

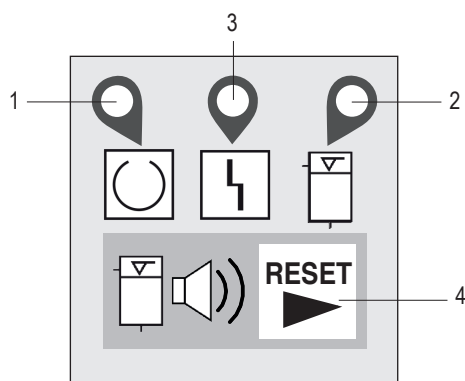

1	LED 1	green glowing	ready for operation
2	LED 2	red flashing red glowing	see 6.2 Error messages
3	LED 3	yellow glowing + buzzer tone switchable via RESET	Level indicator: Container 95% full
		yellow glowing + buzzer tone that cannot be switched off via RESET	Level indicator: Container 100% full
		yellow flashing yellow glowing	see 6.2 Error messages
4	RESET	No colour	RESET button When the container is 95% full, the buzzer tone can be switched off by pressing the RESET button.

6.2. Error messages



Assembly, modifications and repairs may only be carried out exclusively by authorised specialist personnel (see 3.2. Safety instructions)! The METASYS technical customer service is also available for further information and assistance in carrying out repairs, retrofitting, fault analyses, etc.

	LEUCHTEN
	BLINKEN

Error message	Externe Anzeige	Possible cause	Countermeasures
LED 1 glows green LED 2 flashes red Buzzer tone		Capacitive sensor interrupted or short circuit. Valve interrupted or short circuit. Motor not connected.	Notify your service technician.
		collection container not inserted correctly.	See 7.2.1 to insert the collection container correctly.

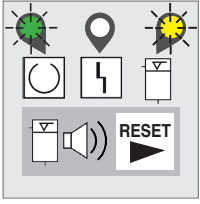
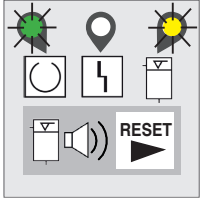
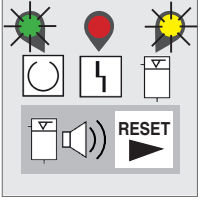
Error message	Externe Anzeige	Possible cause	Countermeasures
<p>LED 1 flashes green LED 3 flashes yellow</p> <p>Buzzer tone can be switched off via RESET</p>		<p>Motor overtemperature</p>	<p>Notify your service technician.</p>
<p>LED 1 glows green LED 3 glows yellow</p> <p>+ buzzer tone can be switched off via RESET</p>		<p>collection container 95% full</p>	<p>collection container replacement recommended, continued operation up to 100% possible.</p> <p>The buzzer sound can be switched off by pressing the RESET key. LED 3 remains lit as a reminder. Buzzer tone sounds again each time the main switch is switched on (see 7.2.1. Replacing the collection container and 7.2.2. Disposing of the collection container).</p>
<p>LED 1 glows green LED 3 glows yellow</p> <p>+ Buzzer tone cannot be switched off via RESET</p>		<p>collection container 100% full</p>	<p>Collection container must be replaced. Further operation is not possible due to the blocking of the place selection valve (see 7.2.1. Replacing the collection container and 7.2.2. Disposing of the collection container).</p>
<p>Centrifuge does not switch off automatically and is permanently in operation.</p>	-	<p>Error capacitive sensor</p>	<p>Clean sensor Replace sensor Notify your service technician.</p>
<p>Centrifuge does not start</p>	-	<p>Error capacitive sensor</p>	<p>Check sensor connection Replace sensor Notify your service technician.</p>
<p>Suction flow is not released</p>	-	<p>Suction flow valve defective</p>	<p>Clean or replace suction flow valve Notify your service technician.</p>
<p>Bubbles form in the container when pump (module 2) is in operation</p>	-	<p>Reassemble or replace pump housing or filter</p>	<p>Pump housing or filter missing or disassembled Notify your service technician.</p>
<p>Pump capacity not sufficient</p>	-	<p>Filter for pump missing or disassembled</p>	<p>Reassemble or replace filter Notify your service technician.</p>

7. Care and maintenance

7.1. Regular cleaning measures

For trouble-free operation, briefly operate the spittoon bowl flushing after each treatment and flush each suction hose with cold water to remove residues from the lines.

The following cleaning measures must be carried out regularly:

Measure	Interval	
Cleaning and disinfection of the suction system	2 x daily	see 7.1.1. Daily cleaning with GREEN&CLEAN M2
Cleaning and emptying the prefilter	At least 1 x per week, depending on workload, emptying may also be necessary daily	see 7.1.2 Cleaning and emptying the prefilter
Container replacement	If required / at least 1 x per year	See 7.2.1. Replacement of the collection container and 7.2.2. Disposal of the collection container

7.1.1. Daily cleaning with GREEN&CLEAN M2

2 x daily (noon/evening) and after surgical interventions, disinfection must be carried out with the prescribed disinfectant and cleaning agent GREEN&CLEAN M2. Ideally, GREEN&CLEAN M2 should be used prior to the treatment unit remaining at a standstill for extended periods (lunchtime, end of the day or holidays). For information on use and safety instructions, see the GREEN&CLEAN M2 instructions for use.

7.1.2. Cleaning and emptying the prefilter

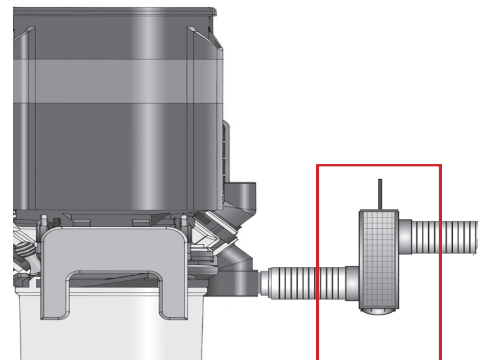

- 1 Collect the residues containing amalgam from the filter drawer in a suitable container.

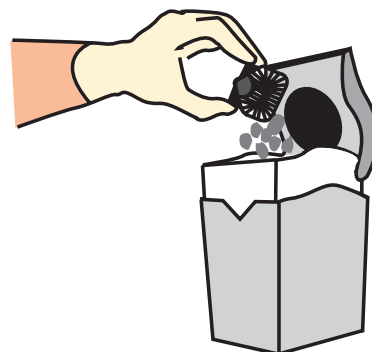

7.2. Maintenance and service



Assembly, modifications and repairs may only be carried out exclusively by authorised specialist personnel (see 3.2. Safety instructions)! For further information and assistance in carrying out repairs, retrofitting, fault analyses, etc., the METASYS technical customer service is also available!



Warning:
Switch off the main switch of the treatment unit!



Warning:

Avoid contact with the contents of the amalgam separator!



Warning:

Risk of contamination: To avoid infection, wear personal protective equipment (hand, eye, mouth-nose protection) and disinfect and clean the device!

7.2.1. Replacement of the collection container

- 1 Provide a new collection container and disinfectant.



- 2 Turn the locking clip on the amalgam separator upward. Hold the separator in place.

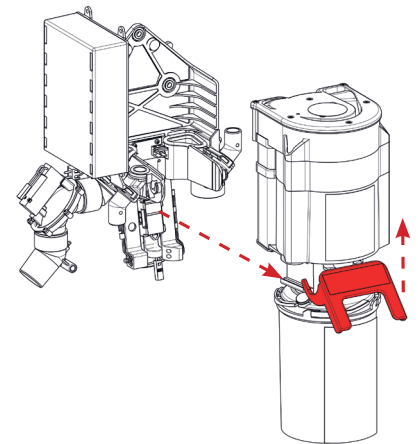

- 3 Pull the amalgam separator forwards out of the fastening element and place it on a flat, non-slip surface.

- 4 Hold the container firmly and turn the upper part counterclockwise. Pull off the upper part upwards.

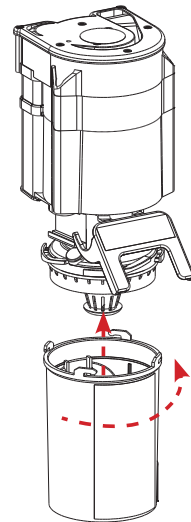

- 5 If the pump filter is dirty, pull it off, clean it over a collecting vessel and then put it back on the suction housing of the pump.

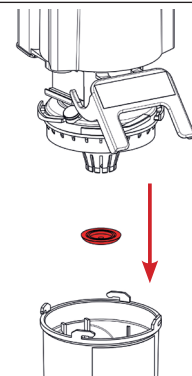

- 6** Place the upper section on the new collection container. Hold the collection container and turn the upper part clockwise as far as it will go; carry out a visual inspection (all retaining lugs of the container must be properly engaged).

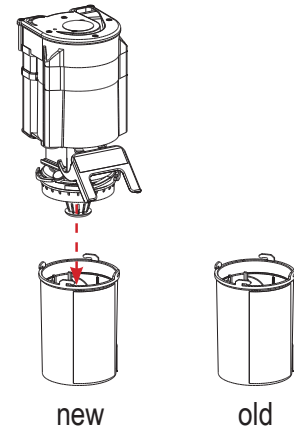

- 7** Grease the sealing surfaces in the retaining element with Vaseline.

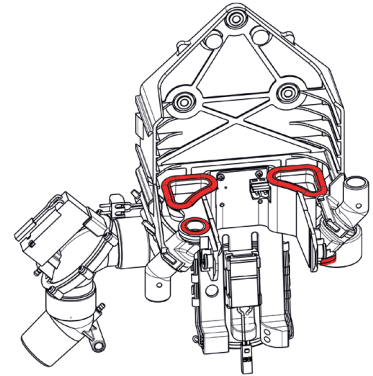

- 8** Carefully push the amalgam separator back into the retaining element and close the locking clip.

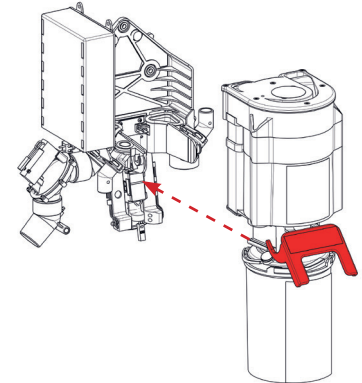

- 9** Switch on the main switch of the treatment unit.
 The unit starts up briefly 1 to 2 times and LED 1 on the external display lights up green („ready for operation“).

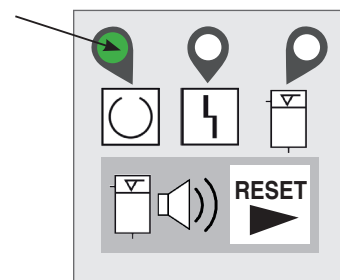

- 10** If the collection container is not inserted correctly, LED 2 on the external display flashes red and a beep is heard. In this case, switch off the main switch and carefully repeat the procedure as described above.

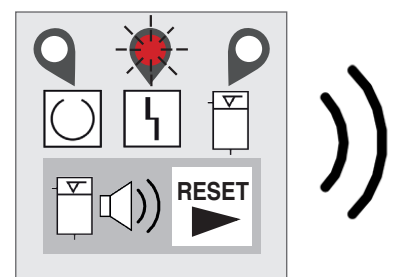

7.2.2. Disposal of the collection container

The full collection container can be returned to the company's own disposal organisation, METASYS logistics & collection GmbH GmbH.

Retain the confirmation of disposal in accordance with state law.

When the complete device is disassembled at the end of its service life, it can be returned to the manufacturer for correct disposal (see 8.2. Recycling and disposal).

Pour disinfectant (10 ml GREEN&CLEAN M2) for suction systems into the full amalgam collection container.

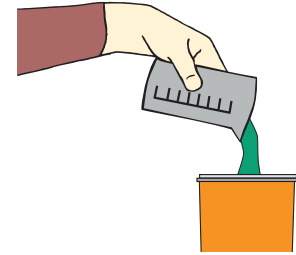

1



Close the full collection container with the green lid by turning it clockwise.

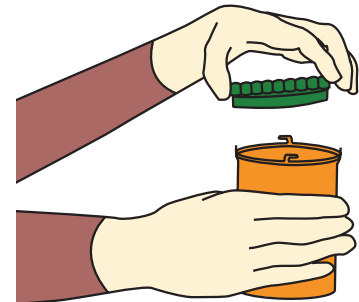

2

Carry out a leak test by placing the closed collection container upside down over a collection receptacle. If necessary, close the cover tightly again.

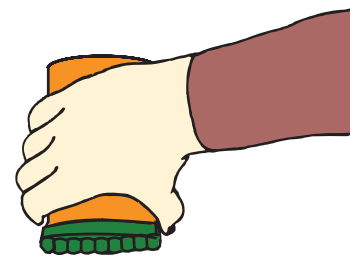

4

Place the properly sealed collection container in the 2 polystyrene half cups and then place it in the transport box.

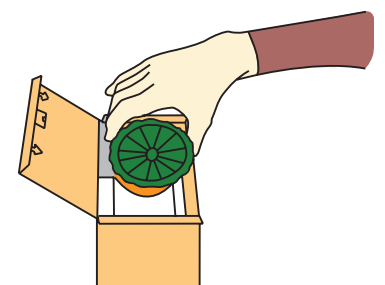

- 5 Close the transport box as per the enclosed instructions.

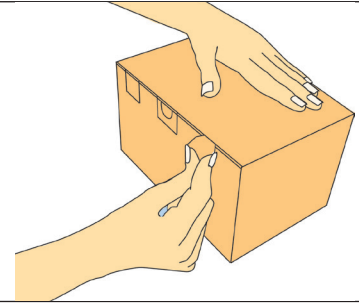

Dispose of the full collection container via an appropriate disposal company.

- 6 For disposal using METASYS logistics & collection GmbH:
Visit www.metasys.com/collection_centers for more information on disposal in your country!

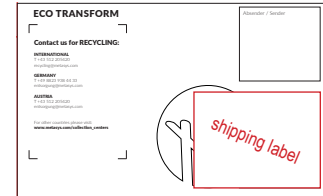

- 7 Stopping residues, filter residues or other waste containing amalgam must be collected in a suitable container and can be disposed of by a disposal company (e.g. METASYS logistics & collection GmbH).

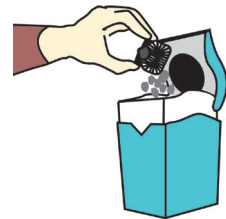

7.2.3. Service mode



The electronics of the COMPACT Dynamic amalgam separator allows the device functions to be checked in a service mode.



Attention:

In order to return to normal operation or service mode after switching off the unit, it is essential to wait 5 seconds before switching it on again!

Activating the service mode

- 1 Press and hold the RESET key during power-up (approx. 5 seconds). LED 1 (ready for operation) flashes (2.5 Hz).
- 2 Release the RESET key, LED 1 continues to flash.
- 3 Press the RESET key again to start the motor.
- 4 Press the RESET button again to stop the motor and control the valve.
- 5 Press the RESET button again to stop the valve.
- 6 By pressing the REST button again, steps 3 to 5 are repeated as often as required.
- 7 The service mode is terminated by switching off the supply voltage.

7.2.4. 1-year service kit

According to the Deutsches Institut für Bautechnik (German Institute for Construction Technology), the display units of amalgam separators must be checked for function at least once a year by an expert!



**METASYS makes it mandatory to carry out the 1-year inspection.
The 1-year inspection must be entered in the device document!**

In the course of the 1-year inspection, we recommend the prophylactic replacement of the following parts by an authorized technician: collection container, seal set, separation rotor, pump filter.

Start service mode

- 1 Call up service mode (see 7.2.3 Service mode)
- 2 Perform motor and valve test run at least once
- 3 End service mode by switching off the supply voltage

7.2.5. 5-year service kit

According to the German Waste Water Ordinance, Annex 50, amalgam separators must be inspected for proper condition at intervals of no longer than 5 years in accordance with state law!

The 5-year inspection must be entered in the device document!

- | | | |
|---|---|---|
| 1 | Carry out a 1-year inspection | see 7.2.4. 1-year service kit |
| 2 | Check the correct installation and connection of the amalgam separator in accordance with the installation requirements | see 5.2. Installation requirements |
| 3 | Carry out disinfection and cleaning of the suction hoses and spittoon | see 7.1.1. Daily cleaning with GREEN&CLEAN M2 |
| 4 | Carry out a visual inspection of the centrifuge chamber | see 7.2.5.1. Visual check of the centrifuge |

7.2.5.1. Visual check of the centrifuge

- 1 Remove separator from wall bracket

Remove the four screws on the top of the unit using a suitable tool (Torx 20).
- 2 Remove the lid of the separation (use the screwdriver support on the back).
Do not remove the separation inlet seal!
- 3 Remove the separation rotor by removing the plug in the center of the rotor using needle-nose pliers, loosen the hexagon socket screw and pull the rotor out upwards.
Attention: Left-hand thread!
- 4 Pull off pump hose on the back of the separator at the upper connection
- 5 Remove centrifuge inlet part upwards (using needle-nosed pliers)
- 6 Pull out the centrifuge chambers upwards

Visually check the centrifuge chambers for contamination; centrifuge chambers that show heavy deposits or accumulations of solids must be replaced!
- 7 Then reassemble in reverse order.

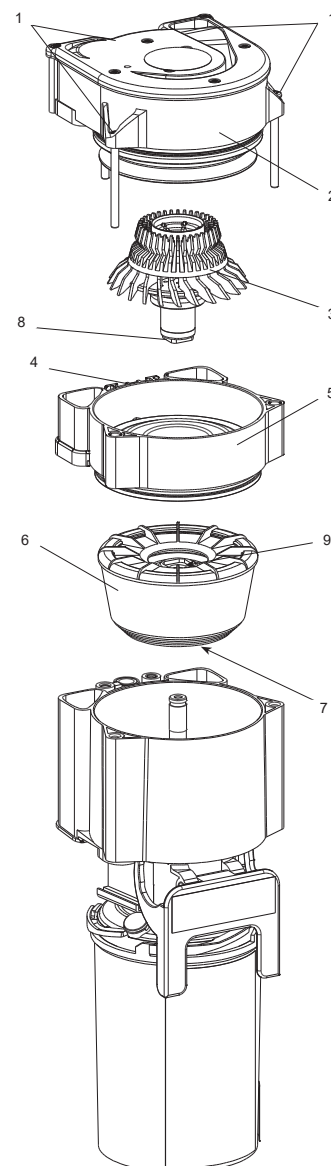

ACHTUNG!

It is important that all screws used are screwed in as far as they will go!

When assembling, make sure that the four pins (7) on the underside of the centrifuge chamber are inserted into the holes provided! Furthermore, the square of the separation rotor (8) must engage in the centrifuge top (9)!

8. Decommissioning

8.1. Disassembly

**Warning:**

Remove from power source before disassembly!

**Warning:**

Risk of contamination: To avoid infection, wear personal protective equipment (hand, eye, nose and mouth protection) and disinfect and clean the device!

If it is necessary to return the device to the depot or to METASYS, the original METASYS packaging must be used. Before packing the METASYS device to be transported, clean and disinfect it. Possible openings where residual fluids could escape must be closed.

8.2. Recycling and disposal



The device may be contaminated! Advise the disposal company of this so that appropriate precautions can be taken. Parts that are contaminated with amalgam, such as filters, filters, hoses, etc., must also be disposed of in accordance with the national regulations.

Uncontaminated plastic parts of the device can be recycled as normal plastics. The integrated electronic components (including circuit board) are to be disposed of as electronic waste. Metal parts are to be disposed of as scrap metal.

Alternatively, the device can be returned to the manufacturer for proper disposal. Before packing the METASYS device to be transported, clean and disinfect it. Possible openings where residual fluids could escape must be closed. The original METASYS packaging must be used for shipping.

The proof of installation and the device logbook must be kept for 5 years after the device has been disposed of.

9. Annex

9.1. Order numbers and scope of delivery

Designation	Designation	Scope of delivery
101000026	COMPACT Dynamic	Amalgam separator with standard accessories and instructions for use
101000027	COMPACT Dynamic / KaVo	Amalgam separator with KaVo accessories and instructions for use
101000029	COMPACT Dynamic / Planmeca	Amalgam separator with Planmeca accessories and instructions for use
101000030	COMPACT Dynamic / OMS	Amalgam separator with OMS accessories and instructions for use
101000031	COMPACT Dynamic / Miglionico	Amalgam separator with Miglionico accessories and instructions for use
101000032	COMPACT Dynamic / a-dec 400/500	Amalgam separator with a-dec 400/500 accessories and instructions for use
101000033	COMPACT Dynamic SIGER	Amalgam separator with SIGER accessories and instructions for use
101000034	COMPACT Dynamic / a-dec 300	Amalgam separator with a-dec 300 accessories and instructions for use
101000035	COMPACT Dynamic a-dec 200	Amalgam separator with a-dec 200 accessories and instructions for use
101000036	COMPACT Dynamic KaVo 1066, KaVo1063, KaVo1065	Amalgam separator with KaVo 1066 / KaVo1063 / KaVo1065 accessories and instructions for use
101000037	COMPACT Dynamic / Planmeca	Amalgam separator with Planmeca, Kaladent accessories and instructions for use
101000038	COMPACT Dynamic / Ancar	Amalgam separator with Ancar accessories and instructions for use
101000039	COMPACT Dynamic / Planmeca Compact i5	Amalgam separator with Planmeca Compact i5 accessories and instructions for use

9.1.1. Accessories, service kits, collection containers and spare parts

CD = Abbreviation for COMPACT Dynamic

Spare parts

Designation	Designation
120000558	ET COMPACT Dynamic/ECO, locking bracket
120000559	ET COMPACT Dynamic/ECO, immersion probe
120000560	ET COMPACT Dynamic/ECO, plug spittoon bowl drain, 5 pcs
120000561	ET COMPACT Dynamic/ECO, separation upper part
120000562	ET COMPACT Dynamic/ECO, separation rotor
120000563	ET COMPACT Dynamic, place selection valve
120000564	ET COMPACT Dynamic/ECO, sliding ring set
120000565	ET COMPACT Dynamic/ECO, delivery water/air
120000566	ET COMPACT Dynamic/ECO, sealing plugs separation rotor, 5 pcs
120000567	ET COMPACT Dynamic/ECO, connections water/air, 2x 2 pcs
120000568	ET COMPACT Dynamic, centrifuge chamber
120000569	ET COMPACT Dynamic, water/air transfer
120000570	ET COMPACT Dynamic, wall bracket
120000571	ET COMPACT Dynamic, suction line prefilter
120000572	ET COMPACT Dynamic, transition board
120000573	ET COMPACT Dynamic, adapter kit
120000574	ET COMPACT Dynamic, safety clip
120000575	ET COMPACT Dynamic, fuse T 6.3 A, 5 pcs.
120000576	ET COMPACT Dynamic, hose clamp set, 2x small, 2x large
120000577	ET COMPACT Dynamic, pump housing
120000578	ET COMPACT Dynamic, pump filter, 5 pcs.
120000579	ET COMPACT Dynamic, Planmeca, installation kit

Designation	Designation
120000580	ET COMPACT Dynamic, Planmeca, circuit board adapter plug
120000581	ET COMPACT Dynamic, Planmeca, cable
120000582	ET COMPACT Dynamic, air inlet valve
120000583	ET COMPACT Dynamic, light sensor
120000584	ET COMPACT Dynamic, KaVo, connection cable board CD2
120000585	ET COMPACT Dynamic, cascade inlet spittoon
120000586	ET COMPACT Dynamic, capacitive sensor, cable 450 mm
120000587	ET COMPACT Dynamic, capacitive sensor, cable 260 mm
120000588	ET COMPACT Dynamic, installation kit
120000589	ET COMPACT Dynamic, main board
120000591	ET COMPACT Dynamic, power unit
120000592	ET COMPACT Dynamic, a-dec, mounting plate
120000619	ET COMPACT Dynamic, siphon floor model
120000620	ET COMPACT Dynamic, Planmeca, CD4 circuit board adapter plug
120000621	ET COMPACT Dynamic, power unit, Nov.

Service kits

120000598	ET COMPACT Dynamic, annual inspection kit
120000597	ET COMPACT Dynamic, annual inspection kit, DE
120000596	ET COMPACT Dynamic, annual inspection kit, hygiene kit
120000595	ET COMPACT Dynamic, annual inspection kit, hygiene kit, DE
120000594	ET COMPACT Dynamic, 5-year inspection kit
120000593	ET COMPACT Dynamic, 5-year inspection kit, DE

Collection container / Replacement container

113000002	EB COMPACT Dynamic, replacement container, AT
113000004	EB COMPACT Dynamic, replacement container, AU
113000005	EB COMPACT Dynamic, replacement container, CH
113000006	EB COMPACT Dynamic, replacement container, CZ
113000007	EB COMPACT Dynamic, replacement container, CZ MIWAS
113000008	EB COMPACT Dynamic, replacement container, DE
113000010	EB COMPACT Dynamic, replacement container, FI
113000011	EB COMPACT Dynamic, replacement container, FR
113000012	EB COMPACT Dynamic, replacement container, HU
113000013	EB COMPACT Dynamic, replacement container, INT
113000014	EB COMPACT Dynamic, replacement container, IT
113000015	EB COMPACT Dynamic, replacement container, NO
113000016	EB COMPACT Dynamic, replacement container, PL
113000017	EB COMPACT Dynamic, replacement container, SI
113000018	EB COMPACT Dynamic, replacement container, SK
113000066	EB COMPACT Dynamic, spare container, GR

Disinfectant

122000026	GREEN&CLEAN M2 - intro kit, 2 x bottle 500 ml + dispenser
122000027	GREEN&CLEAN M2 - refill kit 1, 4 x bottle 500 ml

122000028	GREEN&CLEAN M2 - refill kit 2, 2 x bottle 500 ml
122000031	GREEN&CLEAN M2 red, 25 x bottle 500 ml
122000030	GREEN&CLEAN M2 green, 25 x bottle 500 ml
121000009	GREEN&CLEAN M2 dispenser

Nozzles and adapters

120000057	ET fittings, angle piece clean water outlet 15 mm
120000058	ET fittings, VITALI, connection parts set
120000059	ET fittings, T-distributor for 2 suction hoses
120000060	ET fittings, transport plug Ø 26, 2 pcs.
120000061	ET fittings, Siemens, reducer 15/21 mm, 5 pcs.
120000062	ET fittings, hose adapter 90°, 15 mm, 5 pcs.
120000063	ET fittings, hose adapter 24-25 mm, 5 pcs.
120000064	ET fittings, hose adapter 21-22 mm, 5 pcs.
120000065	ET fittings, hose adapter 19-20 mm, 5 pcs.
120000066	ET fittings, hose adapter 18-19 mm, 5 pcs.
120000067	ET fittings, hose adapter 15-16 mm, 5 pcs.
120000068	ET fittings, hose adapter 15 mm, 5 pcs.
120000069	ET fittings, hose adapter 13 mm, 5 pcs.
120000070	ET fittings, hose adapter 31-32 mm, 5 pcs.
120000071	ET fittings, inlet frame connector 24-25 mm, 5 pcs
120000072	ET fittings, inlet frame connector 20-21 mm, 5 pcs.
120000073	ET fittings, inlet frame connector 19-20 mm, 5 pcs.
120000074	ET fittings, inlet frame connector 18-19 mm, 5 pcs.
120000075	ET fittings, inlet frame connector 15-17 mm, 5 pcs.
120000076	ET fittings, inlet frame connector 15-16 mm, 5 pcs.
120000077	ET fittings, inlet frame connector 10-11 mm, 5 pcs.
120000078	ET fittings, connector 90°, 15 mm, 5 pcs.
120000079	ET fittings, connector 31-21 mm
120000080	ET fittings, connector 25-28 mm, double sealing seat, 5 pcs.
120000081	ET fittings, Dürr Connect, adapter Ø 15
120000083	ET fittings, blind plugs inlet frame
120000084	ET fittings, adapter META Connect, Dürr, large 36 mm
120000085	ET fittings, adapter META Connect pipe connection 50/40 mm
120000086	ET fittings, adapter META Connect pipe connection 36 mm
120000087	ET fittings, adapter META Connect pipe connection 32 mm
120000088	ET fittings, adapter for inlet base body
120000089	ET fittings, adapter 15/26, male
120000090	ET fittings, adapter 15/18, 2 pcs.
120000091	ET fittings, adapter 15/10
120000255	ET META Connect, Y-distributor 26x26x26, male
120000256	ET META Connect, Y-distributor 26x26x26, female
120000257	ET META Connect, air duct extension incl. elbow 72.5
120000258	ET META Connect, air duct extension incl. elbow 64.5
120000259	ET META Connect, air duct extension incl. elbow 56.5
120000260	ET META Connect, air duct extension incl. elbow 49.5
120000261	ET META Connect, air duct extension incl. elbow 31.5
120000262	ET META Connect, extension 72.5 mm

120000263	ET META Connect, extension 64.5 mm
120000264	ET META Connect, extension 56.5 mm
120000265	ET META Connect, extension 49.5 mm
120000266	ET META Connect, extension 27 mm
120000267	ET META Connect, connecting piece hose adapter 26 mm, 5 pcs
120000268	ET META Connect, connection adapter with mini-nozzle, 26 mm
120000269	ET META Connect, T-distributor, male
120000270	ET META Connect, T-distributor, female
120000271	ET META Connect, T-distributor with mini-nozzle, male
120000272	ET META Connect, T-distributor with mini-nozzle, female
120000273	ET META Connect, fitting case
120000274	ET META Connect, safety clip for connectors
120000275	ET META Connect, connector 31-32 mm, 5 pcs
120000276	ET META Connect, connector 26-26 mm
120000277	ET META Connect, connector 24-25 mm, 5 pcs.
120000278	ET META Connect, connector 21-22 mm, 5 pcs.
120000279	ET META Connect, connector 19-20 mm, 5 pcs.
120000280	ET META Connect, connector 17-19 mm, 5 pcs.
120000281	ET META Connect, connector 16-17 mm, 5 pcs.
120000282	ET META Connect, connector 15-16 mm, 5 pcs.
120000283	ET META Connect, connector 10-11 mm, 5 pcs.
120000284	ET META Connect, Dürr Connect system, safety clips, 5 pcs.
120000285	ET META Connect, Dürr Connect System, adapter, male
120000286	ET META Connect, Dürr Connect System, adapter, female
120000287	ET META Connect, double nipple 26 mm
120000288	ET META Connect, angle-piece with mini-nozzles 26 mm
120000289	ET META Connect, connection angle 26 mm
120000290	ET META Connect, connector 45°, suction side
120000291	ET META Connect, connector 45° with air duct
120000292	ET META Connect, connector 45°
120000293	ET META Connect, inlet frame adapter, 5 pcs
120000294	ET META Connect, adapter 26 mm
120000295	ET META Connect, adapter 15/26 mm
120000600	ET Adapter, handpiece small/large, universal
120000601	ET Adapter, 16-11 mm
120000602	ET Adapter for handpiece small, 11-6 mm, soft
120000603	ET Adapter for handpiece small, 11-6 mm, hard

Spare parts - COMPACT Dynamic

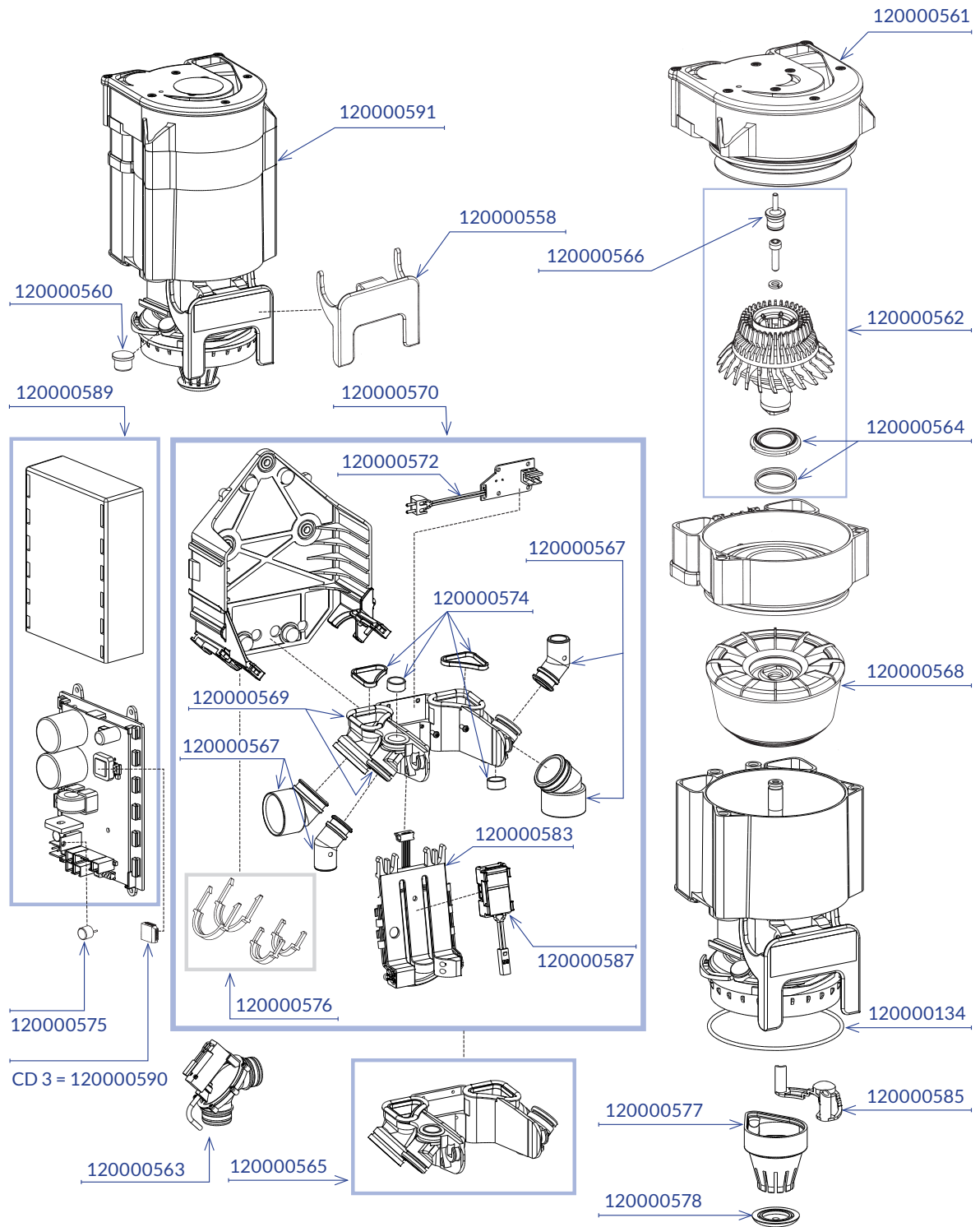

External display - COMPACT Dynamic

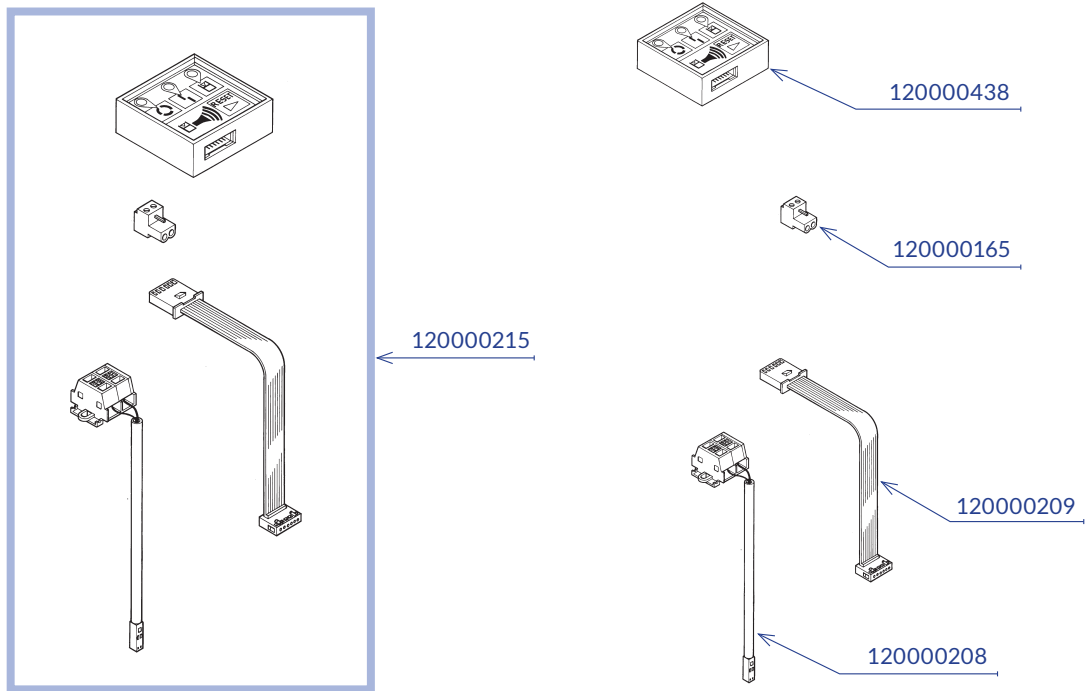

Connection dimensions

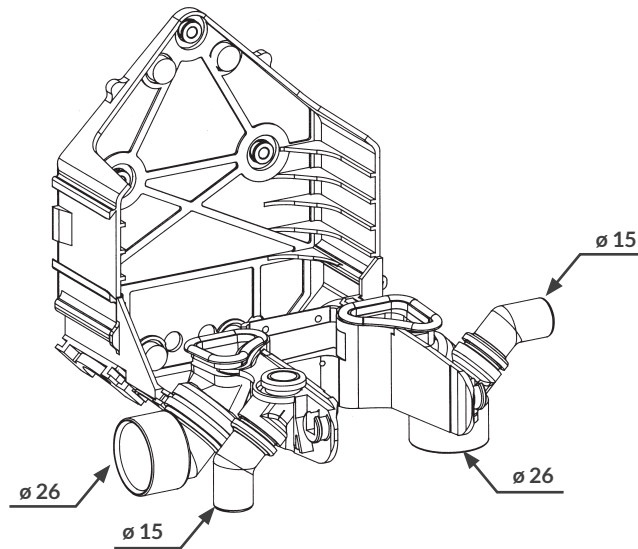

META Connect - hose adapters and adapters

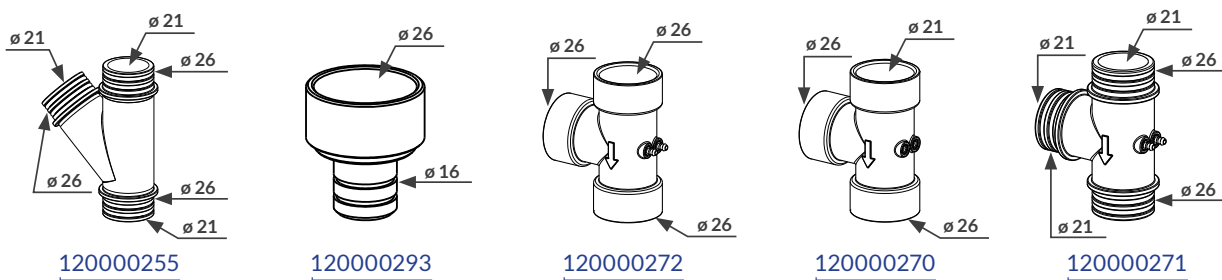
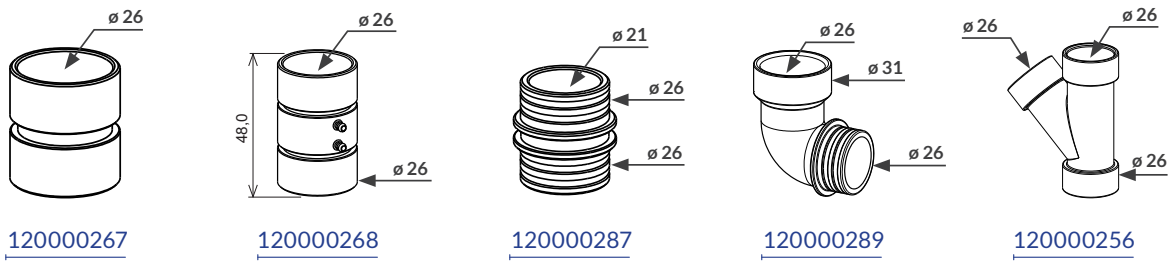
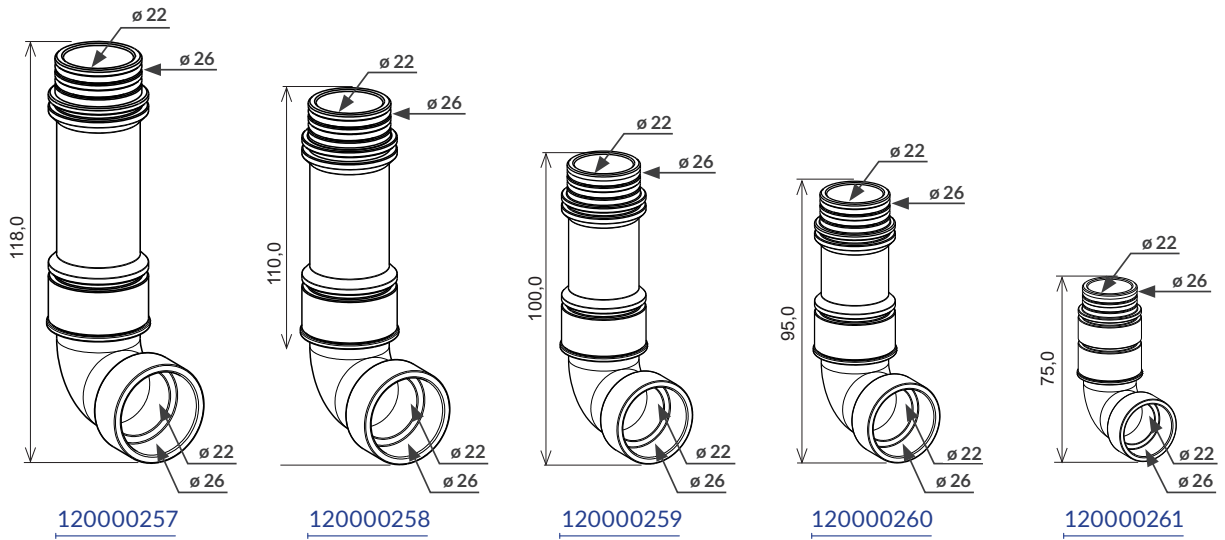
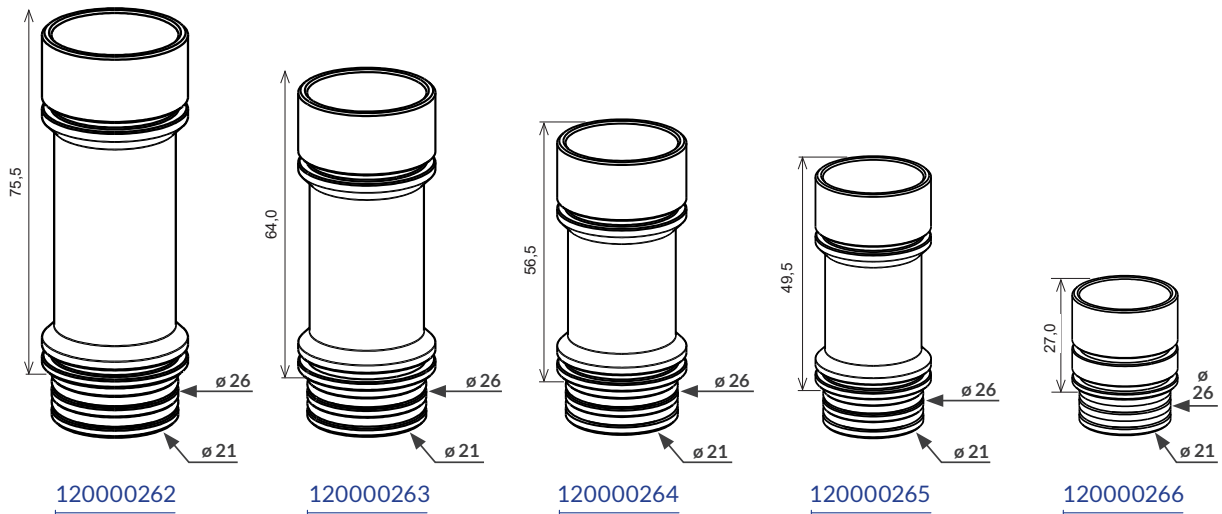

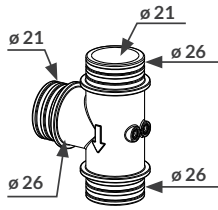

[120000269](#)

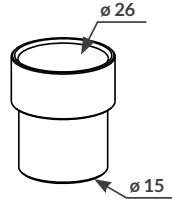

[120000295](#)

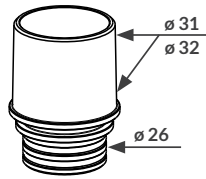

[120000275](#)

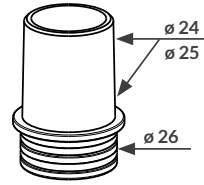

[120000277](#)

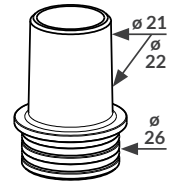

[120000278](#)

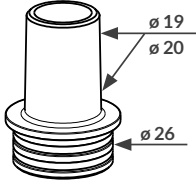

[120000073](#)

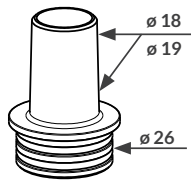

[120000280](#)

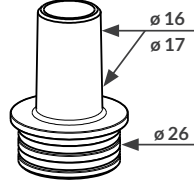

[120000281](#)

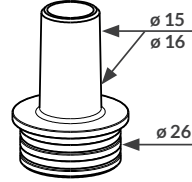

[120000282](#)

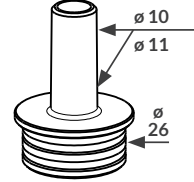

[120000283](#)

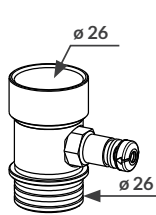

[120000276](#)

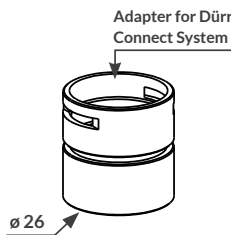

[120000286](#)

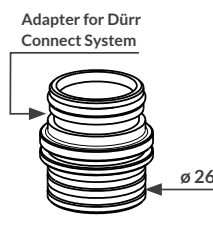

[120000285](#)

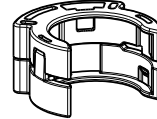

[120000274](#)

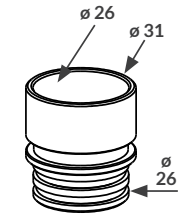

[120000294](#)

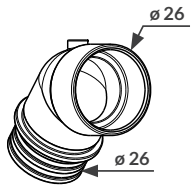

[120000292](#)

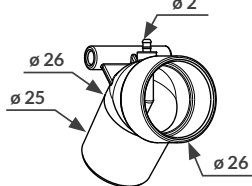

[120000291](#)

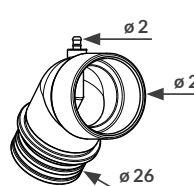

[120000290](#)

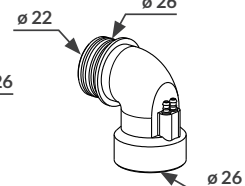

[120000288](#)

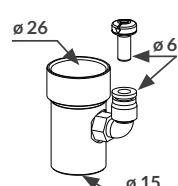

[120000582](#)

hose adapters and adapters combinable with META Connect

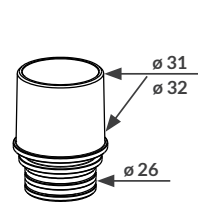

[120000079](#)



[120000060](#)

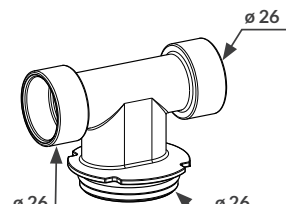

[120000059](#)

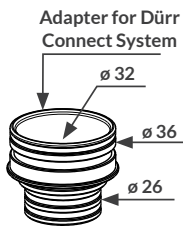

[120000084](#)

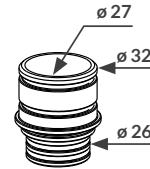

[120000087](#)

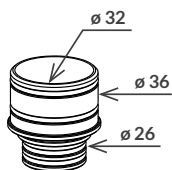

[120000086](#)

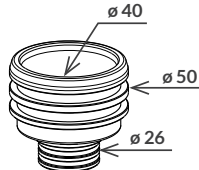

[120000085](#)

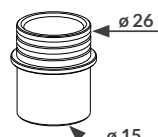

[40010129](#)



[40010122](#)

hose adapters and adapters not combinable with META Connect

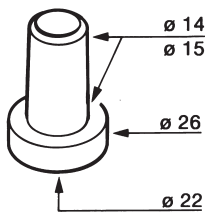

120000067

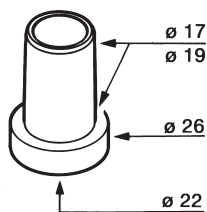

120000066

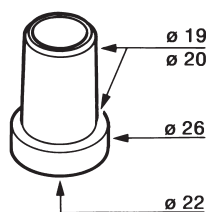

120000065

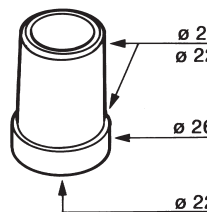

120000064

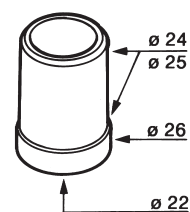

120000063

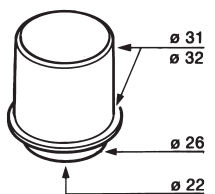

120000070

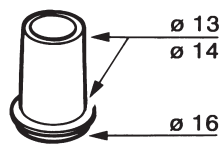

120000069

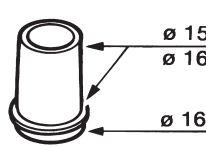

120000068

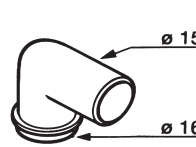

120000062

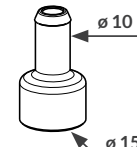

120000091

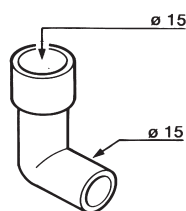

120000057

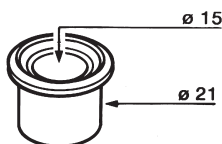

120000061

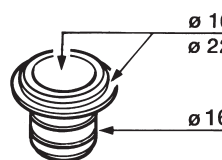

120000088

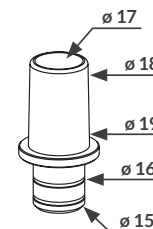

120000074

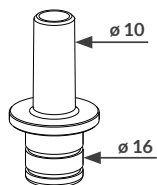

120000077

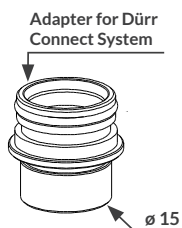

120000081

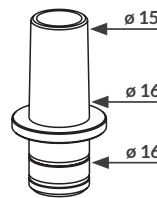

120000076

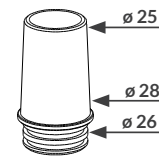

120000080

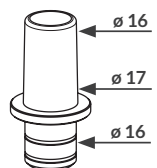

120000075



120000083

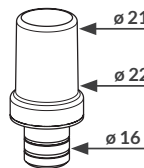

120000072

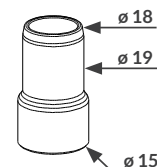

120000090

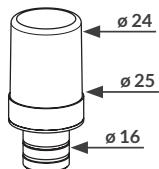

120000071

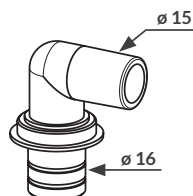

120000078

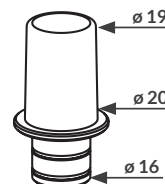

120000073

9.2. Warranty conditions

METASYS grants a guarantee of 12-36 months for specific products (duration of guarantee depends on the product according to the information in the current price list).

The guarantee covers all material faults that more than negligibly affect the function of the device. The guarantee does not cover damages caused by incorrect or improper handling as well as normal wear. Furthermore, the guarantee does not apply to the replacement of the amalgam collection container or to fragile parts such as glass, plastic, hoses, filters, condensate filters or membranes. Any incurred working and travel times are excluded from the warranty.

In order to determine the validity of the guarantee, the installation proof accompanying the device must be returned to METASYS immediately after proper assembly has taken place. In this case the warranty period begins with commissioning. In the event of installation without returning the installation proof to METASYS, any warranty claim is forfeited. Installation and return of installation proof must be completed within 24 months from the date of sale from METASYS.

Furthermore, any warranty claims of the customer expire if only one of the following circumstances arises, regardless of whether the circumstances arise for the customer of METASYS or a later owner or operator:

- > Improper installation, operation, maintenance or transport of the device. If METASYS parts have to be returned, the original METASYS packaging must be used for shipping. Prior to packaging and shipping, the METASYS device must be cleaned and disinfected. Any openings where residual fluids could leak must be closed.
- > Installation and return of installation proof have not been completed in the aforementioned 24 months.
- > Failure to send the Installation Proof to METASYS.
- > Installation and use of non-original METASYS parts.
- > Installation of the device by personnel who are neither trained nor authorized by METASYS.
- > Occurrence of damages through improper handling and operation or use of unapproved cleaning and/or disinfecting material, as well as non-compliance with the instructions for use.
- > Execution of repairs by unauthorised repair shops or unauthorised personnel.
- > Failure to comply with the prescribed maintenance intervals. Maintenance must be carried out 11-12 / 23-24 / 35-36 months after installation of the respective METASYS item.
- > Missing entries in the Equipment Logbook regarding the installation as well as prescribed servicing by technicians trained by METASYS.
- > Failure to take reasonable immediate measures to avoid further damages in the event of a malfunction.
- > Shipping of devices or components to METASYS without proper accompanying paperwork, in particular without error description or invoice for the purchase of the device.
- > Failure to provide visual images (photos, video clips ...) of the METASYS item complained about, as well as of its installation situation and ambient conditions.

METASYS reserves the right to demand the documentation supplied with the device to check the maintenance intervals for the assertion of warranty claims. The processing of warranty claims takes place exclusively according to the following method:

In the event of malfunctions, the device must be opened by an authorized technician, the relevant component taken out and sent to METASYS unopened and cleaned. The customer sends the device or component in question to METASYS at his own expense. METASYS checks whether there is a warranty claim. METASYS will repair the device or component if it is cost-effective. The customer is charged for the costs incurred for the repair, but not the replacement parts covered by the guarantee. The consignment of the device or component to METASYS always represents a repair order for METASYS. For cost estimates for the repair of returned devices, a processing fee* is charged if the warranty period has expired or no warranty case exists. For products inspections only without any cost estimates a processing fee* can be charged. When sending the device or component to METASYS, an error description with all importation information about the device must always be included. The customer of METASYS may only provide payment in advance after consultation with METASYS. Only the affected component is to be sent in (smallest possible unit). If contaminated, intact parts are sent to METASYS without technical necessity, METASYS is entitled to destroy them without separate payment. The new part corresponding to the part to be destroyed is only delivered after a separate order and invoice. In any case, METASYS has the right to handle the guarantee through credit note or the return of new parts without conducting repairs. Guarantee services do not result in an extension of the warranty period nor do they initiate a new warranty period. The warranty period for installed replacement parts ends with that for the originally delivered device. The METASYS customer is obligated to make his customer aware of the conditions regarding the warranty processing. The statutory warranty rights of the customer remain unaffected.

* The current warranty conditions and fees can be found in the current METASYS price list.

9.3. Change history

Revision	Date	Description
200004297	22.09.2023	Newly created.



protect what you need



METASYS Medizintechnik GmbH

Florianstraße 3 | 6063 Rum bei Innsbruck | Austria
T +43 512 205420 | info@metasys.com | metasys.com

Subject to printing and setting errors!